

The Intimidator® ManLock Installation Instructions

For Use With McGard 5/8"-11 or 1/2"-13
Flat Seat Manlocks.

(ie. p/n117151 = 5/8"-11 thread and p/n117150 = 1/2"-13 thread)

• **ATTENTION** •

Since all covers & frames can differ dimensionally, prior to start of this procedure each must be inspected to assure proper installation. This instruction sheet is meant to be a general guideline. Please call with any questions you may have during retrofit.

STEP 1: Secure Cover to Frame. If necessary, place wood wedges, tapered pins, or chisels between cover and frame to hold cover in place during drilling.

STEP 2: Drill 17/32" (for 5/8-11 thread) or 27/64" (for 1/2-13 thread) hole through COVER AND FRAME (Approximately 3" minimum drill depth required to create hole through cover and frame. See Figure 2)

- Drill location approximately 5/16" from edge of cover. (See Figure 1)

STEP 3: Counterbore 1-1/4" diameter to 3/4" depth (See Figure 3).

- **NOTE:** Counterbore depth of 3/4" minimum required to ensure protective cap will be below top of cover when installed. Counterbore depths less than 3/4" will result in protective cap protruding above cover.

• **IMPORTANT NOTICE** •

When drilling the counterbore, the bit must not go completely through the cover. Bolt seating area must be on the cover (See Section A, Figure 3).

STEP 4: Drill Clearance Hole thru Cover ONLY for bolt.

- Use 3/4" drill for 5/8"-11 thread, use 5/8" drill for 1/2"-13 thread.

STEP 5: Tap Hole in Frame.

- 5/8"-11 UNC class 2A thread for 17/32" hole
- 1/2"-13 UNC class 2A thread for 27/64" hole.

NOTE: McGard recommends the use of a **ELECTROMAGNETIC DRILL** for ALL Drilling, Tapping and Counterbore Operations.

STEP 6: Repeat Steps 2 thru 5 for a second bolt to secure cover. Second hole should be 170-degrees from first hole (See Figure 1, marked "X").

STEP 7: Clean Tapped Hole with Compressed Air.

STEP 8: **GREASE THREADS** of MANLOCK BOLTS. **VERY IMPORTANT!**

STEP 9: Using Key Wrench, Install bolts to 75-90 ft-lbs of torque. (Approximately the same torque used on wheel lug nuts).

STEP 10: Install protective plastic caps **HAND TIGHT** to complete installation.

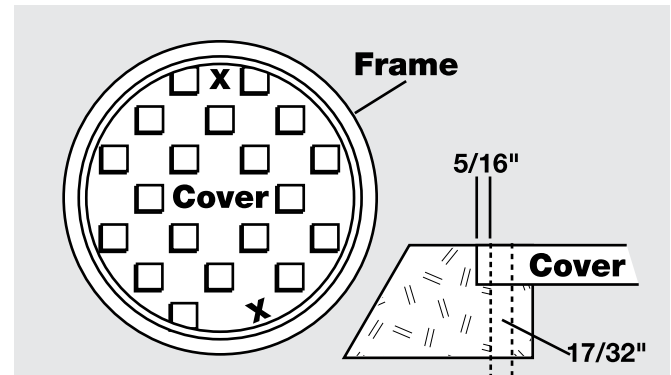

Figure 1

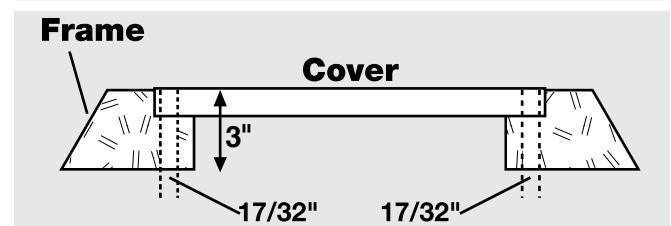

Figure 2

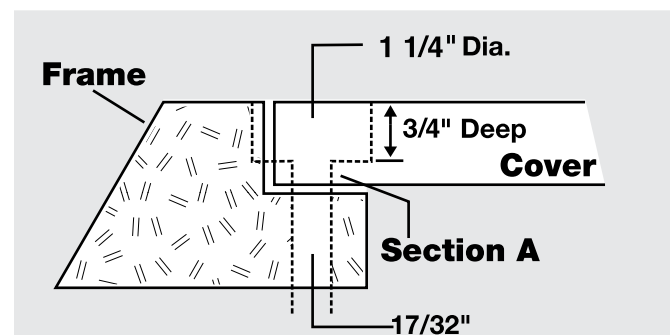

Figure 3

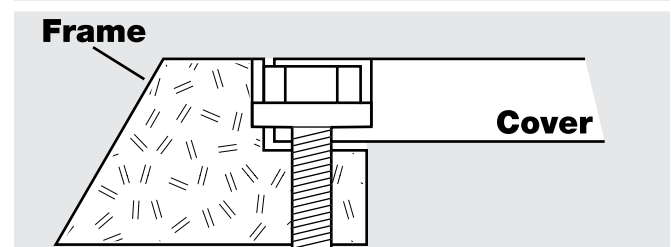

Figure 4

• **NOTE** •

Caps are included with p/n's 117150, 117151.



3875 California Road
Orchard Park, New York 14127-4198
888-888-9192 • fax: 716.662.8985

The Intimidator
Line Of Security Products